

# 15 Series ice and water dispenser with Chewblet® ice machine



## Features

Compact footprint, only 14.62" (37.1 cm) W x 23.50" (59.7 cm) D

15 lb (6.8 kg) ice storage capacity

Integral air-cooled ice machine with up to 125 lb (56.8 kg) daily production of popular Chewblet ice

- designed to serve up to 50 people (160 servings per 10 hr day<sup>1</sup>)
- soft, chewable, compressed nugget ice is preferred over cubes<sup>2</sup>
- environmentally responsible R134a refrigerant with zero ozone depletion potential
- energy saving sleep mode
- quiet production without noisy harvest cycles
- meets the Consortium for Energy Efficiency (CEE) Tier 2 specifications for highly efficient ice machines
- ice-only models now ENERGY STAR® certified

Durable, attractive dispenser

- modern styling, stainless steel exterior with accent trim
- dispense-activated soft blue light illuminates point-of-use
- easy-to-clean, removable 20 oz (591 ml) drip tray
- dispenser top can support 35 lb (15.9 kg)

Designed with sanitation in mind

- Agion® silver-based antimicrobial product protection of key ice and water contact components<sup>3</sup>
- capacitive touch display eliminates direct user contact with ice
- accommodates cups up to 8.80" (22.4 cm) tall

Installation

- comes fully assembled
- two easy connections – electric and water
- drainless design allows dispenser to be placed anywhere a water line can be run and eliminates the cost of a drain installation

Warranty

- 2 years parts and labor, 5 years compressor parts
- optional extended third year warranty (item# 00960732)

## Accessories

- Base stand for converting countertop models (item# 00956292)
  - 4.00" (10.16 cm) leg kit for CI - countertop models (item# 00956300)
  - 6.00" (15.24 cm) leg kit for FS - freestanding models (item# 00956318)
  - Drip tray drain kit for countertop models (includes 4.00" (10.16 cm) legs) (item# 00981977)
  - Drip tray drain kit for freestanding models (item# 00956375)
  - SafeCLEAN Plus™ 15 series single use kit (item# 01054691)
  - SafeCLEAN Plus case of 24 packs (item# 01050863)
  - Cartridge, replacement 5 micron particle/carbon (item# 00968107)
- For additional water treatment and other accessories refer to form# 4025

115 V 60 Hz – ice and water dispensers

Ice storage capacity	Configuration	Filter*	Item number
<b>15 lb (6.8 kg)</b>	countertop ice and water	no filter	<b>15CI100A-IW-NF-ST-00</b>
		internal	<b>15CI100A-IW-CF-ST-00</b>
	freestanding ice and water	no filter	<b>15FS100A-IW-NF-ST-00</b>
		internal	<b>15FS100A-IW-CF-ST-00</b>
	countertop ice-only	no filter	<b>15CI100A-NW-NF-ST-00†</b>
		internal	<b>15CI100A-NW-CF-ST-00†</b>
	freestanding ice-only	no filter	<b>15FS100A-NW-NF-ST-00†</b>
		internal	<b>15FS100A-NW-CF-ST-00†</b>

† ENERGY STAR certified

\* Internal filter is a 5 micron particle and carbon filter

## Specification

Ice storage capacity	15 lb (6.8 kg)
<b>W1</b> Width	14.62" (37.1 cm)
<b>D1</b> Depth of bottom	22.12" (56.2 cm)
<b>D2</b> Depth of top	23.50" (59.7 cm)
<b>H1</b> Height – countertop models	22.50" (57.2 cm)
<b>H2</b> Height – freestanding models	47.00" (119.4 cm)
<b>H3</b> Height, base stand	24.50" (62.2 cm)
<b>H4</b> Dispense height clearance	8.80" (22.40 cm)
Ventilation clearance	3.00" (7.62 cm) on each side
Service clearance	3.00" (7.62 cm) behind and on each side
<b>C1</b> 115 V/60/1 electrical	5 amps. Connect to dedicated 15 amp circuit, fuse or breaker. 8' (2.4 m) cord w/ NEMA 5-15 90° plug.
<b>C2</b> Water inlet	1/4" MPT
Air temperature	50 - 100 F (10 - 38 C)
Water temperature	40 - 90 F (4 - 32 C)
Water pressure	10 - 70 psi (69 - 482 kpa)
Ice production at 70 F (21 C) air and 50 F (10 C) water	125 lb (56.8 kg)
Ice production at 90 F (32 C) air and 70 F (21 C) water	100 lb (45.4 kg)
Energy consumption 90 F (32 C) air and 70 F (21 C) water	6.9 kWh per 100 lb (45.4 kg) ice
Heat rejection	1700 BTU/hr
Water consumption	12 gal (45.4 L) of potable water per 100 lb (45.4 kg) of ice
Approximate shipping weight – countertop models	100 lb (46 kg)
Approximate shipping weight – freestanding models	130 lb (59 kg)
NOTE: For indoor use only. Designed for commercial use. Follett is not able to provide in-house services for residential installations.	

## Dimensional drawing

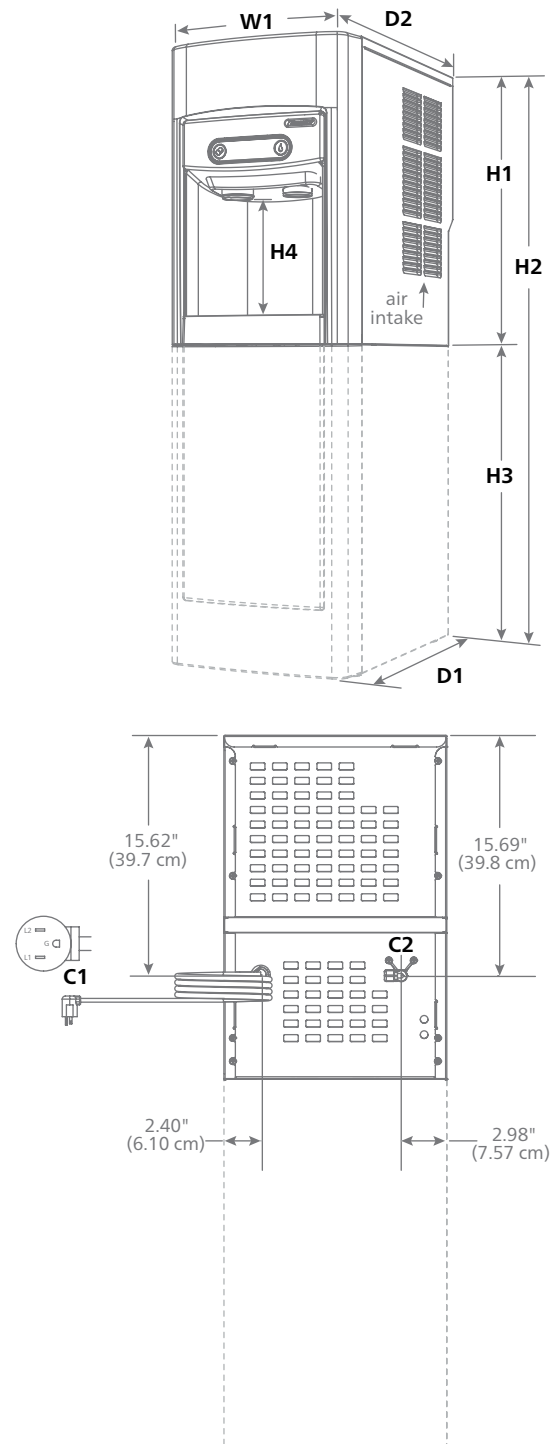

- 1 16 oz (473 ml) cups, 2/3 full of ice.
- 2 Independent third party studies. Contact Follett for details.
- 3 Disclaimer: Antimicrobial protection is limited to the treated components and does not treat water or ice.

Agion is a registered trademark of Sciessent LLC.

ENERGY STAR and the ENERGY STAR mark are registered US marks.

SafeCLEAN Plus is a trademark of the Follett Corporation.

Chewblet and Follett are registered trademarks of Follett Corporation, registered in the US.

Follett reserves the right to change specifications at any time without obligation. Certifications may vary depending on country of origin.

**Leslie**  **WaterWorks**

Toll Free (866) 426-4100 [www.lesliewaterworks.com](http://www.lesliewaterworks.com)

